

ROLAIR[®]
 SCHEMATIC FOR
 5520K17A

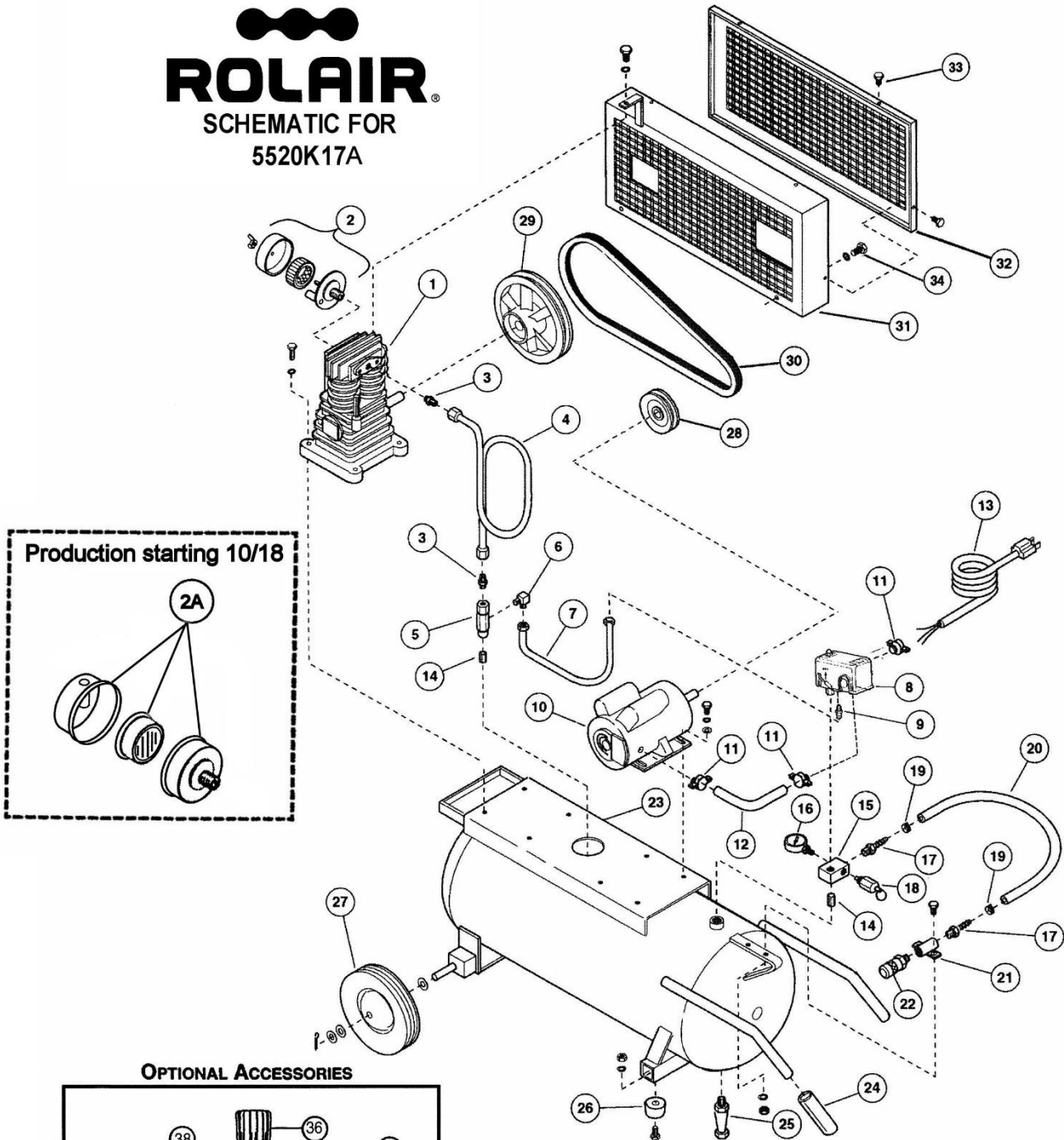

Production starting 10/18

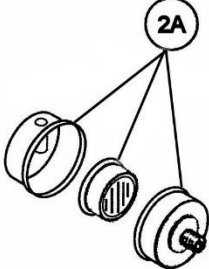
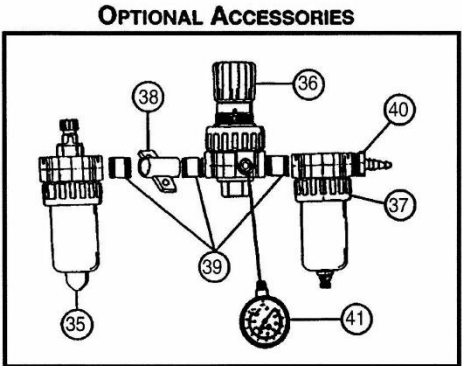
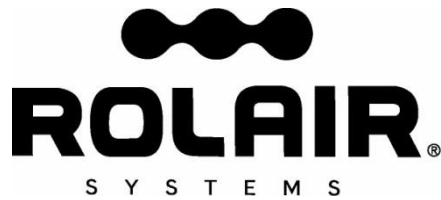

PARTS LIST FOR MODEL 5520K17A

Schematic #	Description	Part #	Qty.
1	Twin Cylinder Pump with Flywheel	PMP12K17CH	1
	Twin Cylinder Pump Less Flywheel	PMP12K17CHLF	1
2	Intake Filter Assembly (before 10/18)	FS14050	1
	Filter Element for FS14050	431	1
2A	Intake Filter Assembly (after 10/18)	FS10052	1
	Filter Element for FS10052	433	1
3	Brass Straight	BRST0500X050038	2
4	Discharge Tube*	5520K17-DISCH TB	1
5	Check Valve**	CV4X4L1	1
6	Brass Elbow	BREL0250X012539	1
7	1/4" Nylon Tubing	Specify Serial Number	1
8	Pressure Switch	PS2020M	1
9	Pressure Switch Relief Valve	PS2020RV	1
10	1.5 HP Motor	MTRC101	1
	1.5 HP Motor w/Dual Voltage Switch	MTRC102	1
11	Box Connector	161	3
12	Cord - 19"	173	1
13	Cord with Plug	170	1
14	Nipple	BLNP0500X1500	2
15	Aluminum Block Manifold***	154	1
16	Gauge - Tank	GA0250200GC	1
17	Brass Coupler	BRCP0375X0375H12	2
18	Safety Relief Valve	SRV0250A165	1
19	Hose Clamp	177A	2
20	3/8" Rubber Hose - 16"	178A	1.34'
21	Accessory Bracket	210	1
22	Quick Disconnect	309A	1
23	20 Gallon Tank Assembly - ASME	TNKASY5520A	1
24	Handle Grip	328	2
25	Drain Valve	132B	1
26	Rubber Foot	219	2
27	Foam-Filled Flat-Free Tire	WLS50	2
28	Pulley	PUAK54X0875	1
29	Flywheel	31007280CH	1
30	Belt	BT4L490/A47	1
31	Belt Guard (Base & Cover)	BG566ASY	1
32	Belt Guard Cover	NLA	1
33	Screw	MIS10093C	4
34	Washer	MIS10108	2
	Lock Washer	MIS10098	2
	Bolt	MIS10004	2
	ACCESSORIES		
35	Lubricator	LUB0375	1
36	Regulator	REG0375	1
37	Filter	FIL0375	1
38	Accessory Bracket	210	1
39	Nipple	BLNP0375X1500	3
40	Brass Coupler	BRCP0375X0375H12	1
41	Gauge - Line	GA0250200GC	1

*Consult factory for discharge tube part # if your unit is equipped with a pulsation chamber.

**Order part #CV4X4L2 if unit is built with dual controls.

***Order part #154D if unit is built with dual controls.

